



Monitoring biosolids to create cost savings

The solutions described provide a number of key benefits to waste water operations and transport management operators. By → *monitoring, reporting and analysing* each movement transaction, the waste water operations team can build a → *concise overview of its operational performance*, providing details of inefficient treatment sites, identification of areas where further investment in treatment or disposal may be required and an understanding of the costs attributed to current practices. The transport management operators can clearly define → *cost saving opportunities* by reducing the movement of inappropriate strength Biosolids, → *validate accurate charging systems* based on actual loads moved and ultimately maximise operational efficiency.



Author:

Ian Procko

- JR Pridham Services Ltd.
- Business Development Director
- Reading Head Office



LANGE 

What to do with 5.6 million tons of sludge?

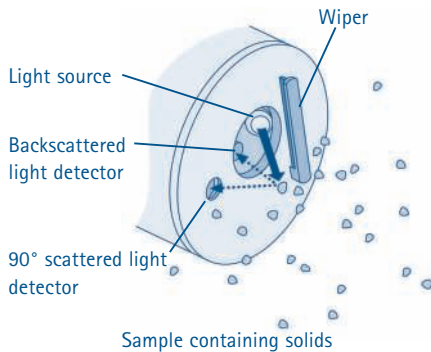

Graph 1: Principle of SOLITAX sc

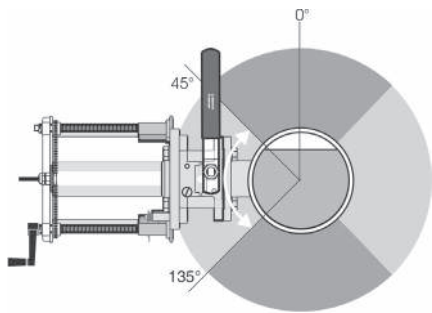

Graph 2: In-pipe installation with the help of safety fitting. Recommended mounting angle 45° to 135°.

Efficient techniques to ensure maximum cost effectiveness

In most cases where on site treatment or disposal is not available the transportation of liquid Biosolids is conducted via dedicated road tanker. The management and running costs of operating either an internal or contracted fleet to conduct inter works Biosolids movement is a costly exercise. Therefore efficient techniques must be adopted to ensure maximum cost effectiveness is achieved.

Many wastewater companies have adopted transport scheduling packages and workload forecasting systems to manage fleet operations and shift patterns, etc. These systems assist in generating efficient workflow patterns and resource management. With the help of additional monitoring technology and refined reporting techniques now available, the UK Water Industry have been able to analyse these Biosolids movements in far greater detail. Providing further opportunity for decreasing inefficiency and enhancing cost reduction in the transportation of liquid Biosolids.

Preferred choice of JRP: SOLITAX highline sc

JR Pridham Services Ltd (JRP), a Berkshire based UK wastewater contractor, provide the market leading 'WaSP' Tanker Reception solution which delivers complete control, monitoring and visibility for all Biosolids movements with enhanced data gathering and analysis capabilities. The 'WaSP' system utilises the SOLITAX highline sc probe within each discharge line and the SC 100 digital controller to provide sludge content measurements during the discharge transaction.

The 'WaSP' controls the cleaning arm of the SOLITAX sc probe

ensuring that the unit is cleaned at the start and at the end of each transaction. Minimising any potential system downtime and dealing with inaccuracies or maintenance issues. The units are regularly inspected and verification tests are performed on homogenous sludge samples in conjunction with the wastewater company to ensure repeatability etc. The programmable range of the SOLITAX sc probe (0–15 % sludge content) has made the unit the preferred choice of JRP for a variety of similar applications.

By monitoring the tanker exports from outlying source wastewater works and other locations and the subsequent deliveries into dedicated treatment reception facilities, Biosolids management personnel can clearly define the volumes and strengths of liquid Biosolids being transported throughout the business.

641,000 cubic metres of liquid sludges

were tankered by road in 2006 by a typical Water company in the UK (only 75 % of these were logged using 'WaSP' tanker reception systems). Some UK companies predict large increases in sludge production in the future. In some cases increases of up to 40 % by 2015 but this may be offset against initiatives in improving sludge quality production and hence helping to reduce volumes.

The ability to clearly define the volumes and strengths of the product being transported provides a number of cost saving benefits; the client can clearly measure the exact volumes being transported by internal transport assets or external contracted resources and any charges levied can be accurately substantiated based on exact volumes moved, etc.

Cost savings of £500,000 in the first year

The implementation of a sludge logging scheme, where 23 single and multiple line ‘WaSP’ logging systems were installed, generated cost savings of approximately £500,000 in the first year after installation. As well as clearly measuring the volumes being transported, in addition, by driving efficiency throughout the Biosolids management process, the data provided by the monitoring solutions clearly identified poorly performing sites where inappropriate Biosolids were being removed by road tanker. Inefficient Biosolids movements can severely impact on transport management budgets. Where overly thickened Biosolids is transported by road this can lead to issues regarding increased loading / unloading. In contrast, transporting weak Biosolids

concentrations, with very high water content, is extremely inefficient and costly.

Through the use of source site and/or reception site monitoring, be it vehicle mounted or fixed asset versions, inefficient sites can be clearly identified and local processes can be adapted to modify Biosolids densities to a level more suitable for bulk road transportation. The visibility provided by continuous Biosolids transport monitoring can be invaluable in understanding and evaluating how sewage works are performing and assisting in promoting changes in technology. Or modifying the techniques used to create good quality wastewater Biosolids.



WaSP tanker logging terminal



SOLITAX highline sc installed as insertion probe



Multiple tanker stations

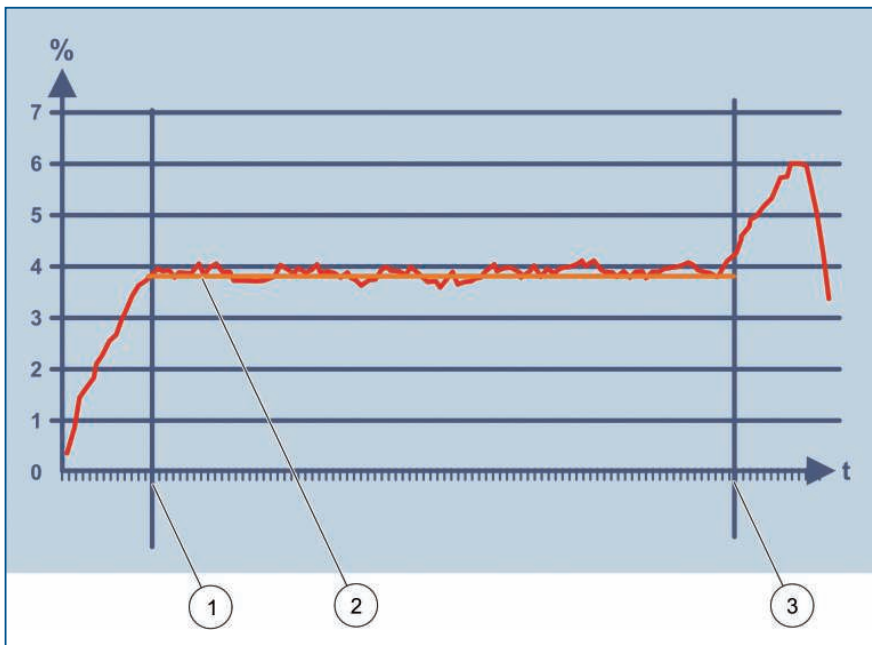

Graph 3: Typical sludge tanker transaction

- 1 – Start of logging process following 300 litres discharged
- 2 – Rolling average % ds logging (readings taken every 5 seconds)
- 3 – Last 30 seconds of data disregarded

Process instrumentation

Overall, following the 'WaSP' system implementation scheme as discussed

- There has been an increase in % ds by between 0.5 and 1.1 % for biosolids transported
- Reductions in transport costs making up a significant element of the £500,000 first year savings.

The savings generated from these initiatives can be applied across the business to ensure processes and procedures for Biosolids management are continuously challenged and developed.

The complete transport process is made visible

The monitoring facilities provided by JRP not only deliver accurate measurements for Biosolids volumes and concentrations. They also provide control solutions for tanker driver access management and sophisticated desktop and web based reporting and visualisation tools. The intelligent facility control systems can provide instantaneous information regarding transactional details via GSM/GPRS communications and can also interface with local site SCADA. JRP also produce similar systems for Trade Waste, Septic and leachate discharge applications.

The savings produced by continuous Biosolids transport process monitoring can be significant and have already proved hugely beneficial in the UK.

HACH LANGE Services



Ordering, information and advice:
UK: +44 (0)161 872 14 87
IRL: +353(0)1 460 25 22
EU: +49 (0)211 52 88-0



On site technical support.



Seminars and workshops:
Practical and hands on training.



Showcasing latest technology and instruments in the HACH LANGE trailer.



Service packages and extended warranty up to 5 years.



www.hach-lange.com
Up to date and secure, with downloads, information and e-shop.

Installed process instruments

Turbidity and solids sensor: SOLITAX highline sc

Self-cleaning stainless steel (V4A) process probe with combined infrared absorption scatter light method. Very low turbidity values as referred to in DIN EN 27027. Values are precise, reliable and colour independent for high sludge contents up to 150g/l suspended solids. Available without wiper cleaning system. Evaluation via SC 100 display unit for one or two process probes or SC 1000 for up to eight process probes.

SC 100 Controller

Digital Controller for wall, in-pipe or control-panel mounting. Two digital sensors can be connected via splashproof connectors. Two analogue power outputs, three potential-free changeover switches (5A 115/230 VAC, 5A 30 VDC), digital interface for bus connection (ModBus, ProfiBus, LonBus).

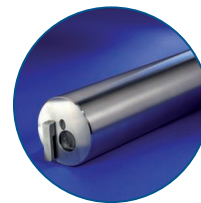

Insertion probe
SOLITAX highline sc



SC 100 Controller

HACH LANGE LTD
Pacific Way
Salford
GB-Manchester, M50 1DL
Tel. +44 (0)161 8721487
Fax +44 (0)161 8487324
info@hach-lange.co.uk
www.hach-lange.co.uk



Phone: (0161) 872 14 87



LANGE